



# The Medlite Home Care Bed

## Owner's Assembly and Operating Manual



*Medline Home Care Beds*  
Full-Electric Bed Model MDR107003L  
Semi-Electric Bed Model MDR107002L  
Manual Bed Model MDR107000P

**DEALER:** This manual must be given to the user of the Medline Home Care Bed.

**USER:** Please read this manual completely for warnings, proper assembly, maintenance, and safe usage instructions before using this bed. Save manual for future reference.

***Congratulations on your selection of the Medline Home Care Bed.***

***Medline's Home Care Bed is the right choice for value and performance. It is specially designed for easy assembly and operation, and is manufactured to precise quality standards with the finest materials.***

***We sincerely hope it will provide the very best in functionality, comfort, rest and convenience.***

***Thank you for choosing the Home Care Bed.***

**Typical Product Specifications for the Medline Home Care Bed:**

	<b>Full Electric 3 motor</b>	<b>Semi-Electric 2 Motor, 1 Crank</b>	<b>Manual 3 Crank</b>
<b>Model Number</b>	MDR107003L	MDR107002L	MDR107000P
<b>Head Ends</b>	Min: 28.5" Max: 35.75"	Min: 28.5" Max: 35.75"	Min: 28.5" Max: 35.75"
<b>Foot Ends</b>	Min: 26" Max: 33"	Min: 26" Max: 33"	Min: 26" Max: 33"
<b>Fabric Height</b>	Min: 14.5" Max: 22.5"	Min: 14.5" Max: 22.5"	Min: 14.5" Max: 22.5"
<b>80" spring overall bed</b>	Length: 89" Width: 35.75"	Length: 89" Width: 35.75"	Length: 89" Width: 35.75"
<b>Spring Deck Width</b>	34.5"	34.5"	34.5"
<b>Spring Deck Height</b>	Min: 14.5" Max: 22.5"	Min: 14.5" Max: 22.5"	Min: 14.5" Max: 22.5"
<b>Shipping Weight lbs.</b>	176.5	173	189
<b>Weight Capacity lbs.</b>	450	450	500
<b>Head Section Adjust</b>	Approximately 75°	Approximately 75°	Approximately 75°
<b>Knee Section Adjust</b>	Approximately 40°	Approximately 40°	Approximately 40°
<b>Motor</b>	DC Input	DC Input	NA

---

 **WARNING**

**TO ENSURE YOUR SAFETY IN USING THIS MEDLINE HOME CARE BED, ALL WARNINGS AND SAFETY INFORMATION AND ALL INSTRUCTIONS MUST BE FOLLOWED. FAILURE TO DO SO MAY RESULT IN SERIOUS BODILY INJURY OR DAMAGE TO THE BED.**

**DO NOT USE THIS PRODUCT WITHOUT FIRST READING AND UNDERSTANDING THE INSTRUCTIONS CONTAINED IN THIS BOOKLET. IF YOU ARE UNABLE TO UNDERSTAND THE WARNINGS, CAUTIONS OR INSTRUCTIONS, CONTACT A HEALTHCARE PROFESSIONAL, DURABLE MEDICAL DEALER OR TECHNICAL PERSONNEL, OR CONTACT MEDLINE AT**

**1-800- MEDLINE BEFORE USE - OTHERWISE SERIOUS BODILY INJURY OR PRODUCT DAMAGE MAY OCCUR.**

**A QUALIFIED TECHNICIAN MUST PERFORM ANY REPAIR OR CHANGE TO THIS BED OR SERIOUS INJURY MAY OCCUR. TECHNICIANS: DO NOT SERVICE THE BED WITHOUT FIRST READING AND UNDERSTANDING THIS OWNER'S MANUAL. IF YOU ARE UNABLE TO UNDERSTAND THE WARNINGS, CAUTIONS OR INSTRUCTIONS, OR HAVE ANY QUESTIONS, CONTACT MEDLINE AT 1-800- MEDLINE.**

**DO NOT USE ACCESSORIES, PARTS, OR ADAPTERS OTHER THAN THOSE AUTHORIZED BY MEDLINE.**

**WARNINGS/CAUTION NOTICES USED IN THIS MANUAL APPLY TO HAZARDS OR UNSAFE PRACTICES WHICH COULD RESULT IN PERSONAL INJURY AND/OR PROPERTY DAMAGE.**

**SAVE THESE INSTRUCTIONS FOR FUTURE REFERENCE!**

---

## TABLE OF CONTENTS

Product Specifications.....	2
General Warnings.....	3
Table of Contents.....	4
Basic Home Care Bed Terminology	
Full Electric Bed schematic.....	5
Bed schematic Legend / Parts List.....	6
Warnings and Safety Instructions	
General Cautions.....	7
Electrical Cautions.....	9
Weight Limitations.....	10
Unpacking the Bed.....	11
Bed Assembly	
Eight Easy Steps.....	12
Connecting the Two Frames.....	13
Connecting the Spring Fabric.....	14
Installing the Casters.....	15
Installing the Headboard and Footboard.....	16
Patient Hand Control.....	17
Adjusting & Connecting the Head Spring Pull Tube.....	18
Installing the Center Drive Shaft.....	19
Junction Box Connections.....	21
Leveling the Bed.....	21
Bed Operation	
Hand Control: Semi-electric & Full Electric Beds.....	22
Manual Bed Operation.....	23
Emergency Crank.....	23
Optional Bed Rails.....	24
Bed Maintenance	
Cleaning the Bed.....	24
Inspecting the Bed.....	25
Troubleshooting Guide.....	26
Motor Adjustment.....	27
Limited Warranty.....	28

# MEDLITE HOMECARE BED PARTS DIAGRAM

**Full Electric Bed**

See Page 7 for List of Terms

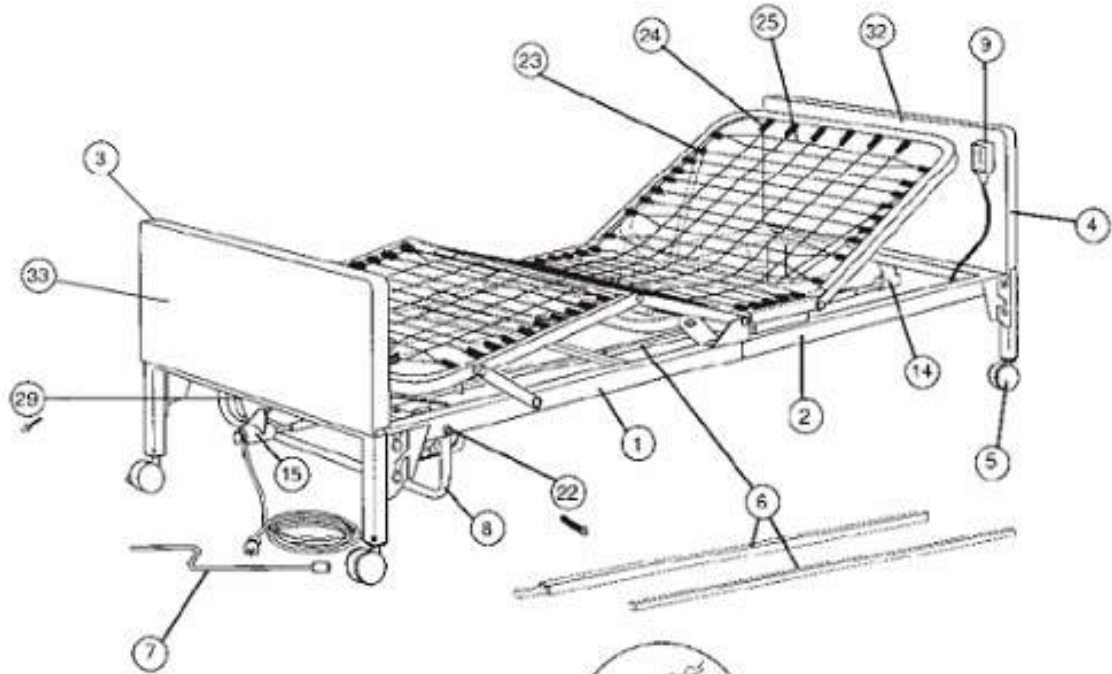

**Head Spring Assembly**

**Foot Spring Assembly**

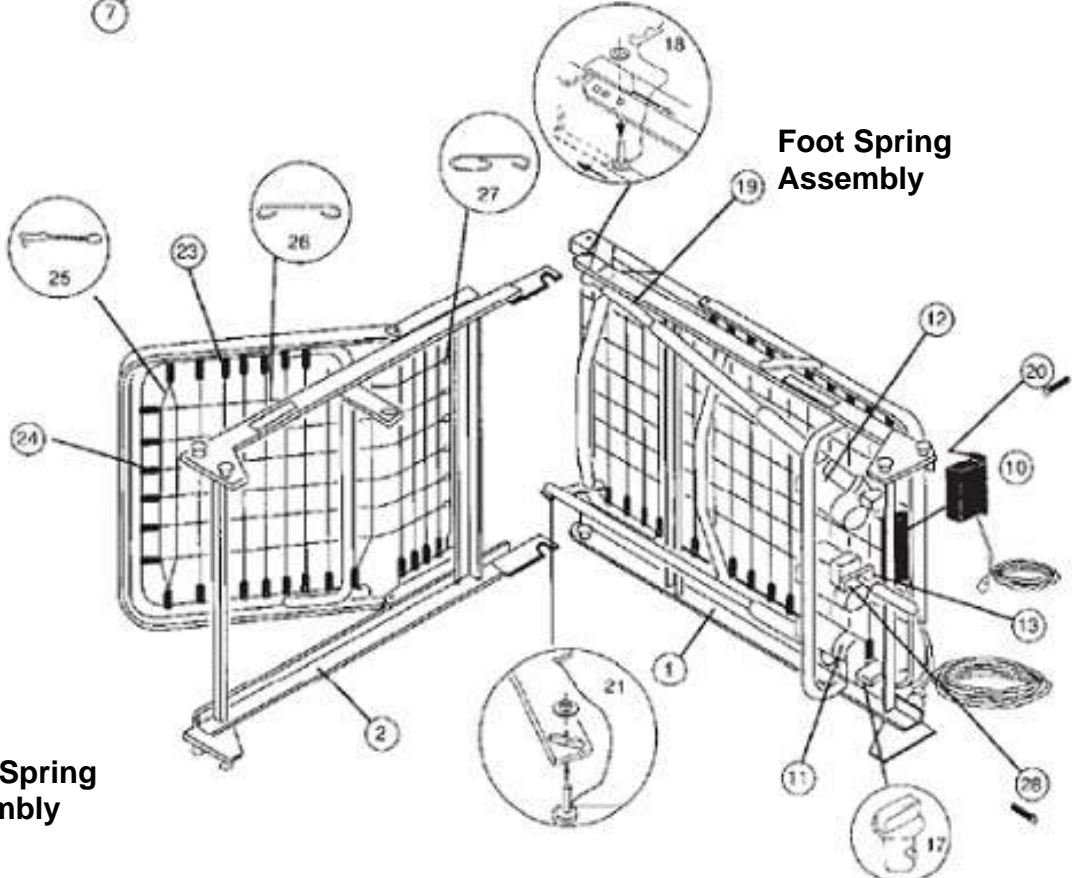

## MEDLITE HOMECARE BED PARTS LIST

### Medline Home Care Bed

Part Number	Description	Bed Style*	Item Number	Quantity
1	Foot Spring Assembly	All	MDR630054	1/EA
2	Head Spring Assembly	All	MDR630114	1/EA
3	Foot Board Assembly	S/M	MDR630014	1/EA
	Foot Board Assembly	F	MDR630314	1/EA
4	Headboard Assembly	All	MDR630024	1/EA
5	Casters- 2 locking, 2 non-locking	All	MDR620034	4/Bx
6	Drive Shaft (Two Pieces)	All	MDR620124	1/EA
7	Emergency Crank Handle	All	MDR620104	1/EA
8	Motor Guard Tube	All	MDR620044	1/EA
9	Pendant With Cord (Two Motor)	S	MDR630094	1/EA
	Pendant With Cord (Three Motor)	F	MDR630154	1/EA
10	Junction Box (2 motor)	S	MDR630084	1/EA
	Junction Box (3 motor)	F	MDR630144	1/EA
11	Motor/ Actuator for Foot Spring	S/F	MDR630074	1/EA
	Handle/ Shaft Assembly for Foot Spring	M	MDR620224	1/EA
12	Motor/ Actuator for Head Spring	S/F	MDR630064	1/EA
	Handle/ Shaft Assembly for Head Spring	M	MDR620214	1/EA
13	Hi-Low Motor Assembly	F	MDR630164	1/EA
14	Gear Box for Head Board	All	MDR620025	1/EA
15	Gear Box For Footboard With Handle	S/M	MDR620015	1/EA
	Gear Box For Footboard No Handle	F	MDR630035	1/EA
16	Handle Assembly For Hi-Low	S/M	MDR620085	1/EA
17	Quick Release Lock for Motor	All	MDR620175	4/Set
18	Fasteners Set for Head Spring Motor	All	MDR620005	1 Set
19	Extension Tube of Head Motor Assembly	S/F	MDR630065	1/EA
	Extension Tube, Handle/ Shaft Assembly	M	MDR620075	1/EA
20	Screw, J-Box	S/F	MDR620095	2/Set
21	Fasteners Set for Head Spring Motor	All	MDR620055	1 Set
22	Screw with Lock Nut for Motor Guard Tube	All	MDR620045	4/Set
23	Springs for head section	All	MDR620105	62/CS
24	Springs for foot section	All	MDR620115	12/CS
25	Mesh Grid for head section	All	MDR620125	204/EA
26	Mesh Grid for foot section	All	MDR620135	259/EA
27	Engaging Clip	All	MDR620145	6/BX
28	Hi-Low Motor Screw	F	MDR630165	2/Set
29	Gear Box Screw	All	MDR620155	4/Set
30	Panel for Headboard	All	MDR630244	2/Set
31	Panel for Footboard	All	MDR620254	2/Set
32	Composite Inserts for Casters	All	MDR620185	4/Set

*Bed Style*      *F= Full-Electric Bed: MDR107003L*  
                      *S= Semi- Electric Bed: DR107002L*  
                      *M= Manual Bed: MDR107000P*

## WARNINGS & SAFETY INSTRUCTIONS



### **General CAUTIONS**

**DO NOT** use this product without first reading and understanding the instructions contained in this booklet. If you are unable to understand the Warnings, Cautions or Instructions, contact a healthcare professional, durable medical equipment dealer or technical personnel, or contact Medline at 1-800- Medline before use - otherwise serious bodily injury or product damage may occur.

Read ALL general guidelines, warnings and cautions before performing any repair / maintenance on the bed. All repair and maintenance on the bed should be performed by a qualified technician. After any adjustments, repair or service and BEFORE use, make sure all attaching hardware is tightened securely.

Inspect all parts for shipping damage before assembly and use. In case of damage, do not use. Contact your shipping carrier immediately for instructions. For any non-shipping issues, contact your Medline Dealer for further instructions.

Do not use near explosive gases. Possible fire hazard when used with oxygen administering equipment other than nasal or masked type.

Use ONLY mask or nasal type oxygen administering equipment around the bed. The use of any other type of oxygen administering equipment can result in a fire hazard.

When using nasal or masked type administering equipment, oxygen or air tubing must be routed and secured properly to ensure that tubing does not become entangled and eventually severed during normal operation of the bed.

When using liquids in or around the bed, caution should be taken to ensure that liquids of any kind are not spilled. If a liquid is spilled in or around the electric bed, unplug the bed immediately before cleaning. Clean up the spill and let the bed or area around it dry thoroughly before using the electric controls again.

Close supervision is necessary when this product is used by or near children or physically challenged individuals.

**NEVER PERMIT ANYONE TO BE UNDER THE BED OR IN BETWEEN THE RAISED BED FRAME COMPONENTS AT ANY TIME.**

Never permit more than one person on/in the bed at any time.

## WARNINGS & SAFETY INSTRUCTIONS



### *General CAUTIONS*

Keep the bed a minimum of 12 inches away from any direct heat source.

When the bed is not going to be used for an extended period, **UNPLUG** electric bed from the wall outlet.

**DO NOT** unplug the power cord from the junction box.

The bed is not designed to be used as a patient transport. When transporting a patient, use an approved patient transport, otherwise injury or damage may result.

When operating or moving the bed, always ensure that the individual in the bed is properly positioned within the bed. **DO NOT** allow extremities to extend beyond the sides or between the bed rails when performing these functions.

After assembly, test to make sure that all sections are properly and securely in place and operate correctly **BEFORE** use.

Ensure that the head and foot spring sections are securely locked to each other and to the head and foot-boards **BEFORE** use.

Ensure that the pendant and power cords are routed and secured properly so the cords do not become entangled, pinched and/or severed during operation of the electric bed. **NEVER** operate the bed if these cords are damaged.

Keep all moving parts and all drive shafts free of obstructions during operation of the bed. (i.e. blankets/sheets, heating blankets/pads, tubing, wiring, etc. and other types of products using electric cords which may get tangled around the bed, legs or optional side rails).

Ensure the bed caster locks are properly engaged to prevent casters from moving whenever the bed is stationary. **ALWAYS** lock the caster locks when transferring into or out of the bed. Inspect the caster locks **BEFORE** using the bed to ensure the locks function adequately. Even with casters properly locked, some floor surfaces will allow the bed to move under some conditions. Use of the bed on such floor surfaces must be evaluated by the care provider.

If any part of the bed is not working properly, call a qualified technician to examine and repair it.



## WARNINGS & SAFETY INSTRUCTIONS



### *General CAUTIONS*

Improper use of some bed accessories (patient restraints, side rails, trapeze devices, etc.) can cause patient injury or death. Consult your health care professional or the accessory manufacturer for proper use instructions.

If using optional bed side rails and bed extension kit, check to ensure they are properly and securely in place **BEFORE** using the bed.

Ensure the mattress is centered on the frame. This will minimize the risk of the occupant becoming trapped between the mattress and the bed rail.

Individuals that cannot prevent themselves from rolling/climbing out of the bed may require alternative safe means of restraint.

Replacement mattresses and bed rails with dimensions different than the original equipment supplied or approved by Medline may not be interchangeable. Variations in bed side rail design and thickness, size or density of the mattress could cause entrapment. Use **ONLY** authorized Medline replacement parts.

For semi-electric and full electric beds, always remove the manual crank before performing electronic functions. If left in place, the crank will turn when the motor is on and could cause personal injury or damage to the bed.

When disassembling the bed, make sure all parts are in the lowest position.



### *Electrical CAUTIONS*

Never operate the bed if it has a damaged cord or plug. If it is not working properly call a qualified electrician.

The beds are equipped with three-prong (grounding) plugs for protection against possible shock hazards. Connect only to a three-prong outlet. Do not defeat the grounding safety feature by using a three-prong to two-prong adapter. If necessary, have outlet ground reliability checked by a qualified electrician.

Never plug into an outlet that is greater than 120 Volts AC.

Keep all cords away from heated or hot surfaces.

Ensure all cables and cords are routed in a way such that they will not become entangled or pinched.

## WARNINGS & SAFETY INSTRUCTIONS



### *Electrical CAUTIONS*

Do not open assemblies such as the motors, hand control unit, junction boxes or electrical control boxes. There are no user serviceable parts inside. Only trained service personnel are qualified to repair these parts. If uncertified individuals perform any work on these beds, the warranty is voided.

Do not use parts, accessories, or adapters other than those authorized by Medline.

Unplug the power cord BEFORE performing any maintenance on the bed.

After installing any connectors into the junction box, be sure the cable plug is secure otherwise injury or damage may occur.

**DO NOT** force connectors into the junction box otherwise injury or damage may occur.

**DO NOT** unplug the power cord from the junction box.

**DO NOT** operate the bed unless the ground wire is attached to frame.



### *Weight Limitations*

The **TOTAL** weight limit of the Medline Home Care Bed (including accessories, mattress, occupant and any other object positioned on the bed) is 450 lbs for full or semi electric beds, and 500 lbs for manual bed.

Never permit more than one person on/in the bed at any time.

Replacement mattresses and bed rails with dimensions different than the original equipment supplied or approved by Medline may not be interchangeable. Variations in bed side rail design, and thickness, size or density of the mattress could cause entrapment. Use **ONLY** authorized Medline replacement parts.

Body weight should be evenly distributed over the surface of the bed. Do not lay, sit or lean in such a way that your entire body weight is placed only on **RAISED** head or foot sections of the bed. This includes when repositioning or transferring in or out of bed.

## UNPACKING THE BED

The Medline Home Care Bed will arrive in two (2) boxes with the following contents:

### **Box 1**

- 1 Head Board
- 1 Head Spring section
- 4 Casters (2-locking, 2-non-locking)
- 1 Manual
- 1 Wrench

### **Box 2**

- 1 Foot Spring section: Full and Semi-Electric Models include motors, a junction box and Electrical cord already attached. Manual Model includes handle cranks on the frame.
- 1 Hand Pendant Control and Cord: Full and Semi-Electric Models only
- 1 Emergency Crank Handle: Full and Semi-Electric Models only
- 3 Hand cranks (Manual bed)
- 1 Foot Board
- 1 Drive Shaft: length adjusts to adapt to Full Electric, Semi-Electric and Manual models

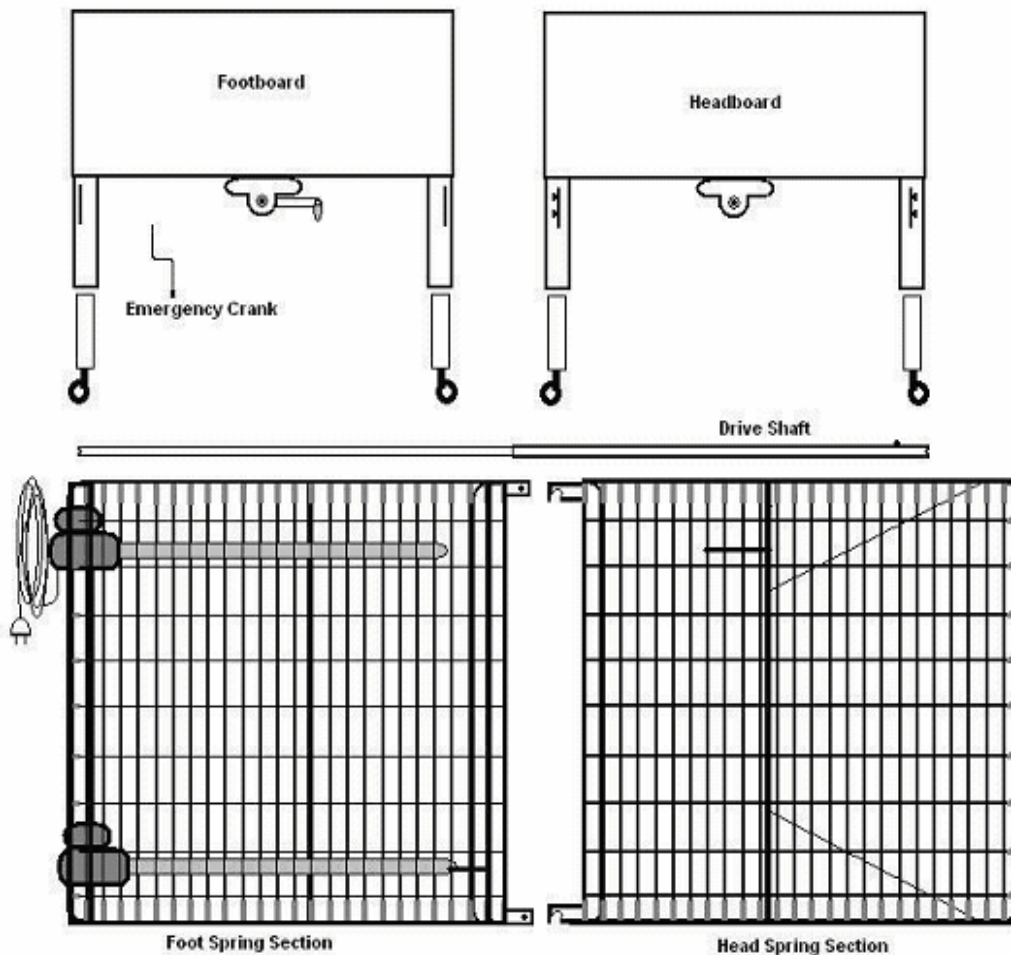

Figure 1: Example of Major Components

## BED ASSEMBLY

Before assembly, examine each item carefully for shipping damage. If a part is found to be damaged, DO NOT use. Contact your Dealer or Medline for instructions.

### **WARNINGS:**

During assembly, **DO NOT** rotate the pull tube or the shaft of the motors; all motors are adjusted to proper position prior to shipping. Rotation will lead to misadjustment of motors which may cause frame damage.

**DO NOT** attempt to operate the bed controls until assembly of the entire bed is complete as damage to bed components or personal injury may occur.

### Bed Assembly Instructions in 8 Easy Steps



1. Connect head section to foot section.



2. Straighten bed assembly.



3. Connect bed assembly to headboard and footboard.



4. Connect center drive shaft.



6. Connect pull tube to head section of bed.



7. Mount bed rails to sides of bed.



8. Place mattress on bed.

See following sections for full assembly instructions.

## BED ASSEMBLY

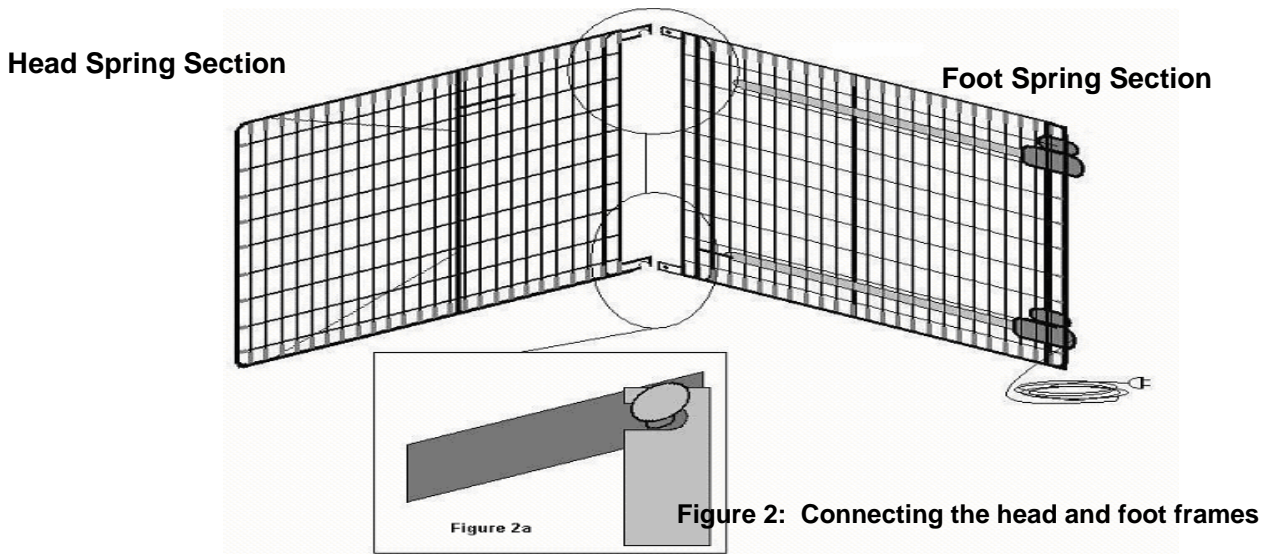

### Connecting the Two Frames: See Figure 2

1. Place the Head Spring Section on its side to your left with the center mounting hooks to your right.
2. Place the Foot Spring Section on its side to your right with the head frame pull tube at the top of the assembly and the center mounting rivets facing to the left.
3. The crank handles and/or motors should be at your right.
4. The head and foot springs should now be on their sides at approximately a 90° angle to one another.
5. Hook the **bottom** head spring center mounting latches to the **bottom** foot spring center mounting rivets. (see Figure 2a)
6. Hook the **top** head spring center mounting latches to the **top** foot spring center mounting rivets. (It may be necessary to lift slightly on the head spring or foot spring to secure the mounting latches and rivets.)
7. After head and foot springs are connected, slowly open the springs into a horizontal (straight) position while still on their sides. Make sure the hooks engage the rivets at all times.
8. Lay the bed flat with the springs facing up.

## BED ASSEMBLY

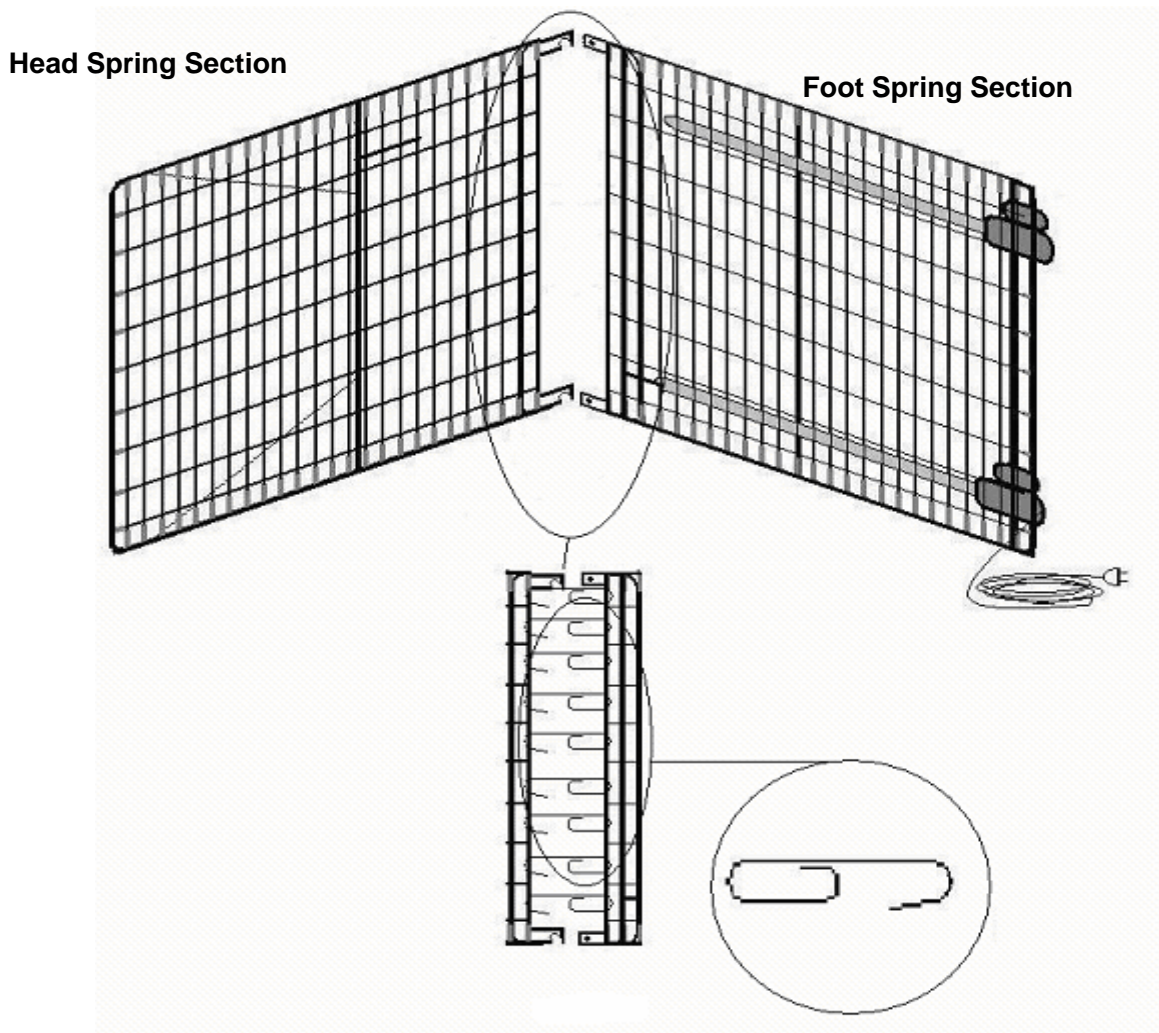

Figure 3: Connecting the spring fabric

### **Connecting the Spring Fabric: See Figure 3**

1. With the bed flat and the springs facing up, lift the head spring section upward to give slack to the fabric. Connect the spring fabric together with the links provided.
2. Hook together all the links to the spring fabric.
3. Lower the head spring section back down.

## BED ASSEMBLY

### To Install Casters

Ensure that the locking casters are installed diagonally from each other and are locked. This will provide maximum locking stability.

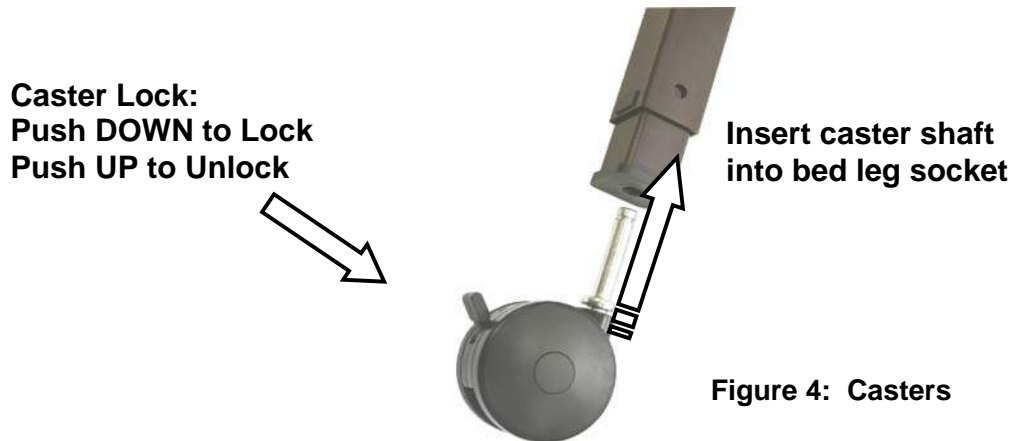

1. Lay the bed ends flat on the floor.
2. Position the two locking casters so they will be diagonally opposite from one another when the bed is assembled. See Figure 4B.
3. Insert the shaft of the caster into the caster socket of each bed leg. Ensure the stem is fully inserted into the socket. See Figure 4.
4. To prevent excess movement of the bed during assembly, lock each of the two locking casters by pushing **down** on the caster lock.

**Note:** Locking the casters may not prevent the bed from moving on slick or slippery surfaces.

5. To unlock the two locking casters, **pull** up on the caster lock.



Figure 4B: Locking Caster positioning

## BED ASSEMBLY

### To Install the Headboard and Footboard

It is recommended that 2 people perform this procedure.

**Caution: Do not place your hand between the spring section and the bed ends while attaching the bed boards as injury may occur.**

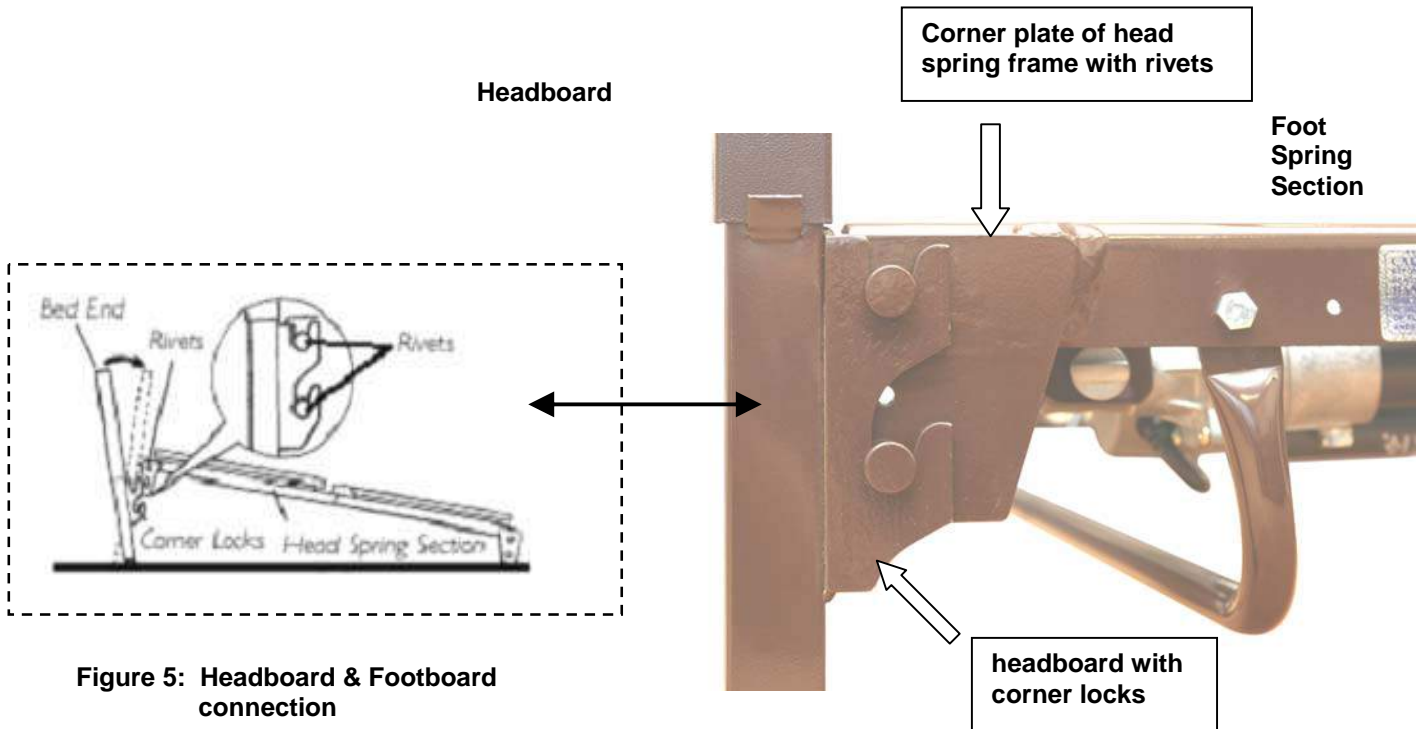

Figure 5: Headboard & Footboard connection

### To Attach Bed Boards

See Figure 5: illustration of attached headboard

1. Stand the headboard as close to the head frame as possible.
2. Raise the head frame until the rivets on the corner plates of the head frame fit into the corner locks on the headboard. The headboard may need to be tilted backward slightly for the rivets to slide into the locks.
3. Return the headboard to its full upright position to lock it into place.
4. Repeat this entire procedure for the foot end section.



# BED ASSEMBLY

## Patient Hand Control

Connect the patient hand control to the bed by inserting the connector into the Junction box and securing it with the Cable Securing Strap once all plugs are connected.



Bed Junction Box

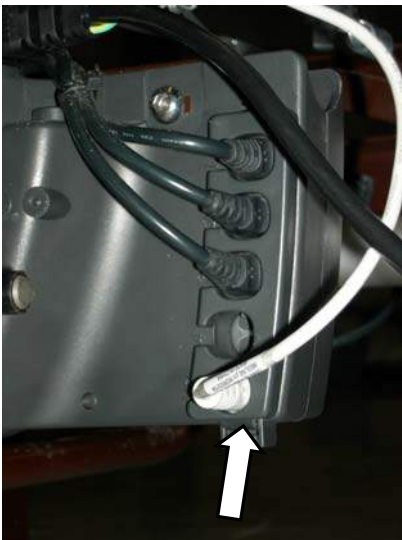

Patient Hand Control Connection

Cable Securing Strap

Figure 6: Bed Junction Box connections

**CAUTIONS:**  
Ensure hand pendant cable is routed in a way such that it will not become entangled or pinched when the bed is adjusted.  
Do not place the pendant hand control under or between objects. This may unintentionally press the buttons which may cause injury or damage to occur.

Hand Control for Semi- Electric Bed



Hand Pendant Connector



Hand Control for Full Electric Bed



Figure 7: Patient Hand Controls

# BED ASSEMBLY

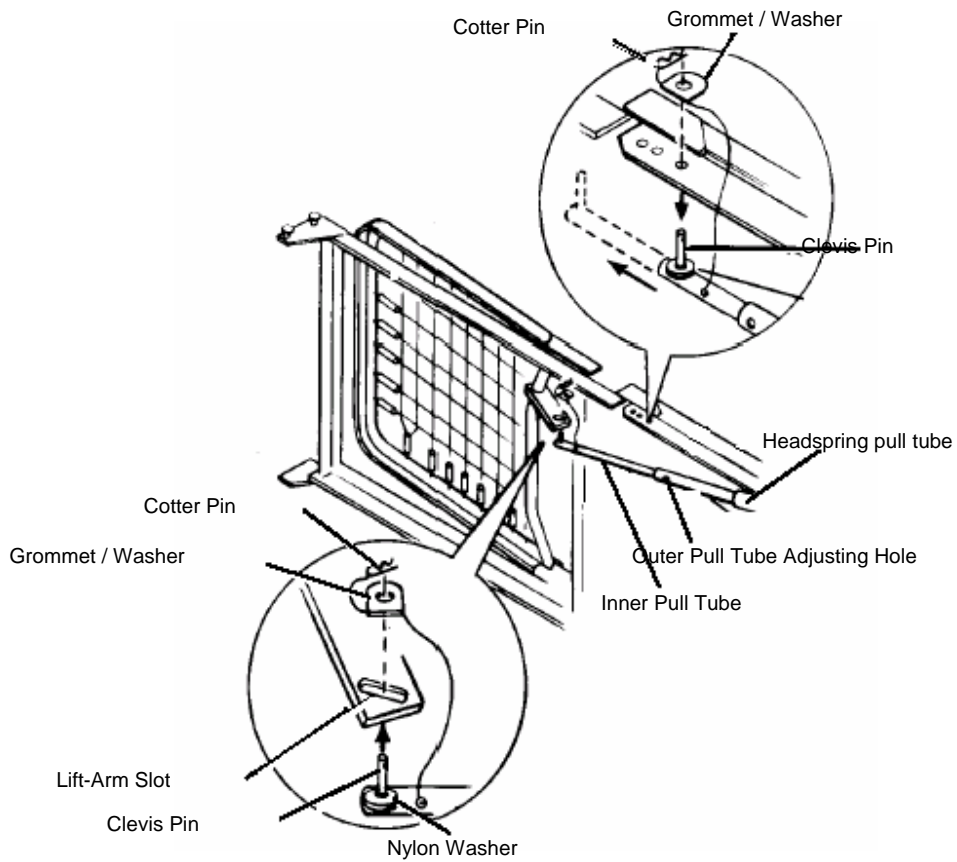

**Figure 8: Head Spring Pull Tube assembly**

# BED ASSEMBLY

## Adjusting and Connecting the Head Spring Extension Tube



**Note:** Early models of the Medline Lite bed utilized a solid tube with a split end for mounting (Type 2). Later models now come with a telescoping tube (Type 1). Please locate which head spring extension tube your bed contains and use the instructions regarding that type of extension tube.

## Adjusting and Connecting the Head Spring Extension Tube

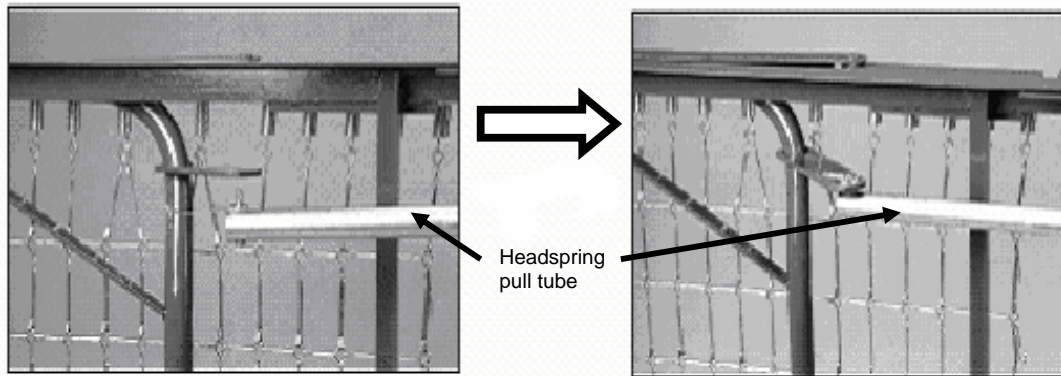

**Figure 9A Type 1 Extension tube attachment**

1. To provide up and down movement of the head section, disconnect the head pull tube assembly from the side frame of the foot spring by removing the cotter pin and washer from the clevis pin.
2. Align the pull tube with the hole on frame.
3. Connect the pull tube assembly to the lift-arm of the head spring by inserting the clevis pin into the lift-arm slot. Reconnect the grommet and washer and secure the cotter pin.

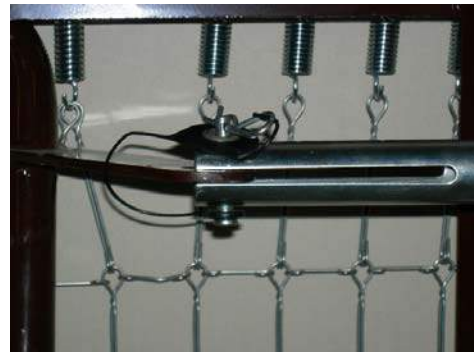

**Figure 9B Type 2 Extension tube attachment**

1. To provide up and down movement of the head section, attach the head extension tube to head spring motor. Make sure tube end with black plastic insert is mounted on motor shaft as shown on right.
2. Pull out extension tube and slide onto frame as shown in Figure 9B.
3. Connect the pull tube assembly to the lift-arm of the head spring by inserting the clevis pin into the lift-arm slot. Reconnect the grommet and washer and secure the cotter pin.



## Installing the Center Drive Shaft

The drive shaft is composed of two sections that are shipped unassembled. The inner shaft, which has a positioning spring button, and the outer shaft, which has two positioning holes and one storage position hole. Together they make the telescoping center drive shaft used on all manual and electric Hi-Lo model beds.

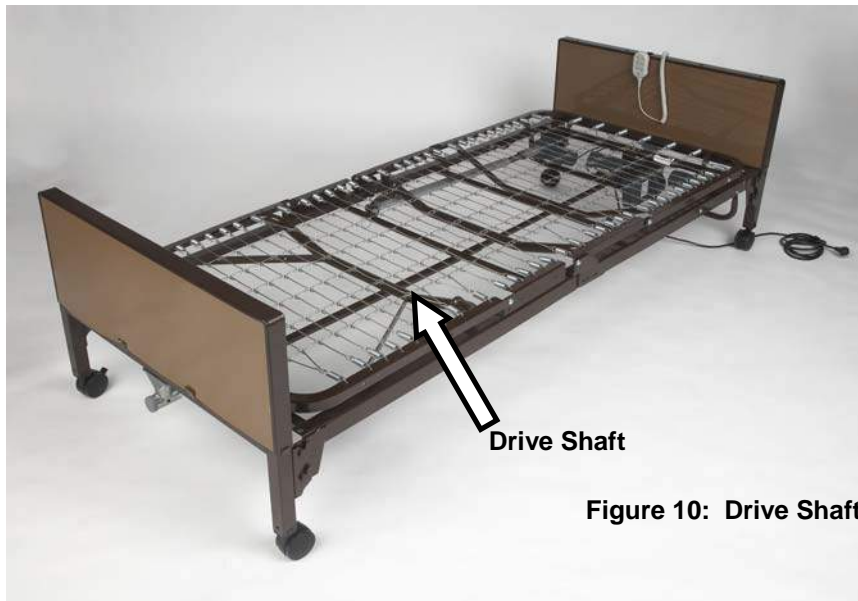

Figure 10: Drive Shaft position

## **BED ASSEMBLY**

## Installing the Center Drive Shaft

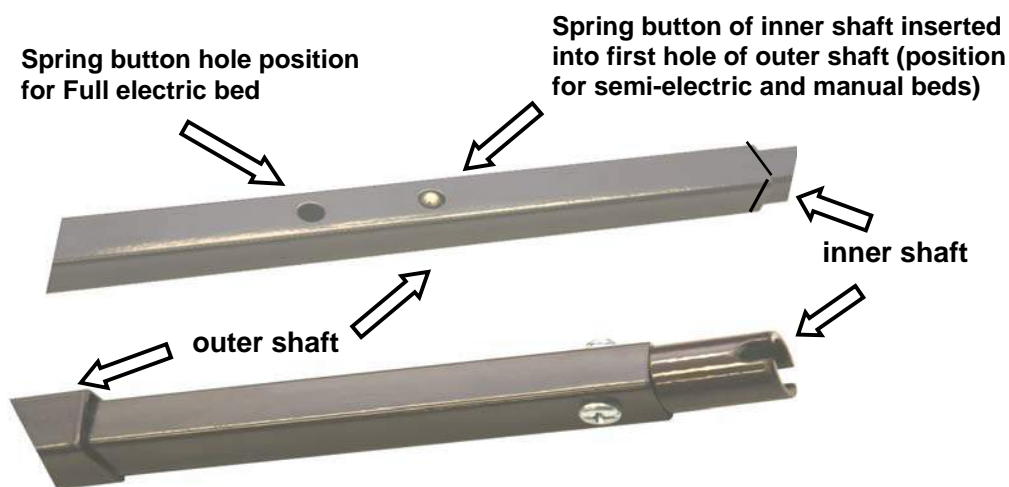

Figure 11: Cut-away detail of drive shaft: inner shaft already placed in outer shaft

1. Depress the spring button on the inner shaft and insert the inner shaft into the outer shaft.
2. Slide the inner shaft to the correct position for the type of bed being used and engage the spring button into the proper positioning hole, as follows:
  - a. For **semi-electric** and **manual** beds: engage the spring button into the first hole position in the outer shaft.
  - b. For the **full electric** model: engage the spring button into the second hole position in the outer shaft.
3. Connect the drive shaft to the bed by attaching either end of the drive shaft to the headboard gearbox. See Figures 11 & 12. Then:

For **semi-electric** and **manual** beds, attach the other end of the drive shaft to the footboard gearbox by pushing the drive shaft toward the headboard gearbox to shorten the length, then fitting the other end into the footboard gearbox.

For **full electric** beds, attach the other end of the drive shaft to the center motor by pushing the drive shaft toward the headboard gearbox to shorten the length, then fitting the other end into the extended shaft of the center motor.

4. Ensure that all components are securely installed.



## BED ASSEMBLY

### Junction Box Connections

1. To insert cords into the junction box, line the cords up with the appropriate receptacle on the junction box and push in until fully seated.
2. Install Cable Securing Strap around wiring as shown.
3. Snap Cable Securing Strap into place using tabs at top and bottom.
4. Check that all cables are secure.
5. Check that ground wire is attached to frame of bed.

**Caution: DO NOT unplug the power cord from the junction box.**

**Caution: DO NOT plug in or unplug any wires unless the bed is unplugged from outlet.**

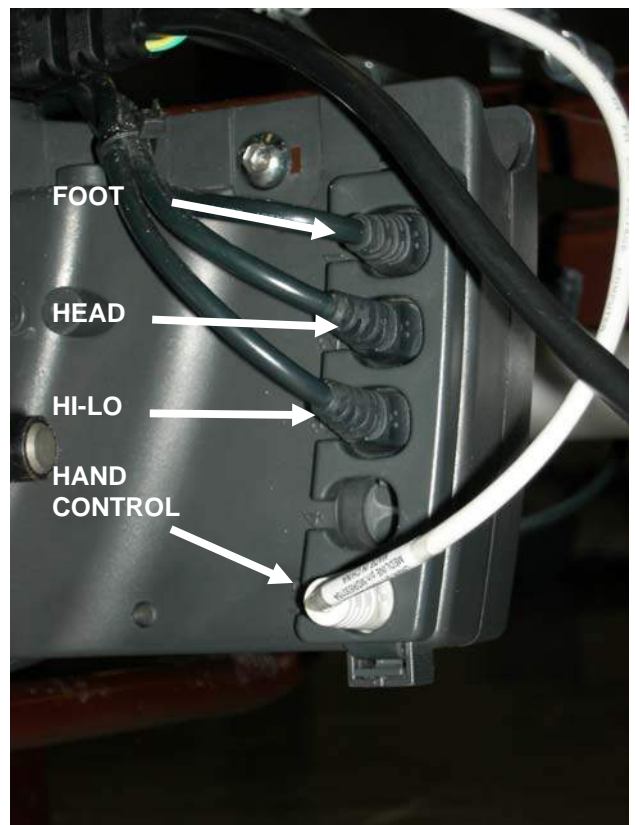

Figure 13: Junction Box, Full-electric bed

## Power Cord

The semi-electric and full electric beds are equipped with three-prong (grounding) plugs for protection against possible shock hazards. Connect only to a three-prong outlet.

Never operate the bed if it has a damaged cord or plug. If it is not working properly call a qualified electrician.

Do not defeat the grounding safety feature by using a three-prong to two-prong adapter. If necessary, have outlet ground reliability checked by a qualified electrician.

Never plug into an outlet that is greater than 120 Volts AC.

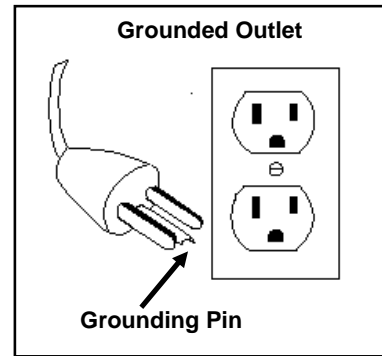

## **BED OPERATION**

### Bed Operation – Hand Control

Allow a slight pause between adjustments and avoid pressing multiple buttons on the pendant hand control at the same time. If buttons are depressed too rapidly or multiple buttons are pressed at the same time, the desired feature may not activate. Simply release the button, permit a slight pause and then activate the next operation.

NEVER operate the bed if the pendant hand control or the power cord is damaged.

Before placing the bed into use, test it by operating it through all phases of its operation.

Check for obstructions or items in the path of the head, foot or bed before operating the hand control.

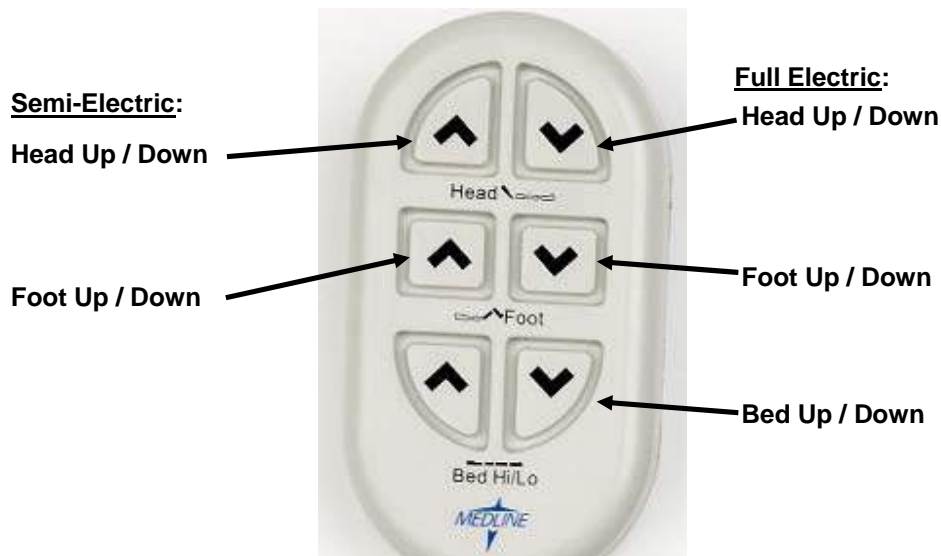

Figure 14: Hand control functions

Plug the bed power cord into a three-prong electric outlet. The patient hand control has four separate functions - raising and lowering the head section and raising and lowering the foot section.

To **raise** the head section, press the button on the left side of the pendant hand control.  
To **lower** the head section, press the button on the right side of the pendant.

To **raise** the foot section, press the button on the left side of the pendant hand control.  
To **lower** the foot section, press the button on the right side of the pendant.

## Leveling the Bed

**Full Electric Bed:** Plug the bed power cord into a three-prong electric outlet. Press and hold the patient hand control's "Bed Raise (Up)" button until the bed reaches its highest position. Next, press and hold the "Bed Lower (Down)" button until the bed reaches its lowest (and safest) position. The bed should be level. See Figure 14.

**Manual or Semi-Electric Bed:** Turn the center Hi-Lo crank counterclockwise. The lowest end of the bed will soon stop moving downward, but the higher end of the bed will continue moving down. When both ends of the bed are at their lowest, your bed is level.

## BED OPERATION

**Manual Beds:** The manual bed features three easy turning cranks for adjusting the bed. The left hand crank adjusts the head section, the right hand crank adjusts the foot section, and the center crank raises and lowers the entire bed (Hi-Lo). Turning the crank clockwise will cause each bed function to raise. Turning the crank counterclockwise will cause each bed function to lower.



**Figure 16: Semi-electric bed: Hi-Lo hand crank shown  
Manual bed: has 3 individual hand cranks  
(not pictured)**

**Caution:** After using any hand crank, be sure to push the handle back so that it fits under the bed and is not sticking out. Leaving the handle out could result in passers by accidentally tripping on the handle.

## Emergency Crank

Semi-electric and full electric beds are equipped with an emergency crank that allows manual bed adjustment in the event of a power failure. The emergency crank is stored in the links of the spring deck. If you did not receive the crank, contact your dealer. Do not leave the emergency crank in place after power is restored and the bed pendant is being utilized.

### To Use the Emergency Crank:

1. Locate the exposed shaft end according to the function you want to perform.

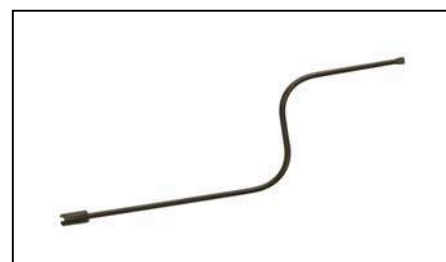
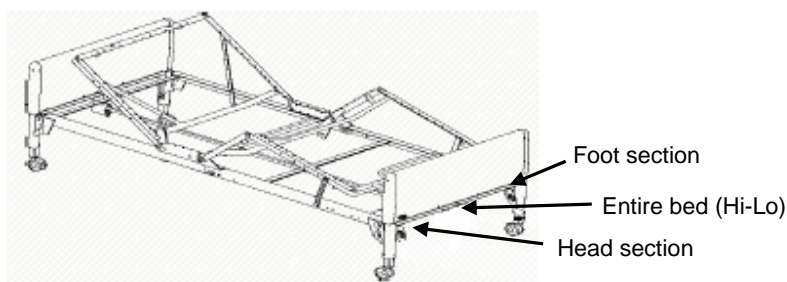

**Figure 16 Emergency Crank and shaft positioning**

2. Attach the emergency crank to the shaft end of the desired function.
3. Push in and turn the crank clockwise to raise the desired function, counterclockwise to lower the function.

## BED OPERATION

### A Word About Optional Bed Rails

Optional bed rails are sold separately and come with an instruction sheet. Do not install the bed rails until you have read and understand all instructions. Variations in bed side rail design and thickness, size or density of the mattress could cause entrapment. Use **ONLY** authorized Medline products. Improper use of some bed accessories such as bed rails can cause patient injury or death.

## BED MAINTENANCE

### Recommended Maintenance of Medline Homecare Beds

The following maintenance practices are recommended for Medline beds. For any questions, please call Medline Bed Technical Support at **1-800-289-9793. Press 1 and then press 3 (from 8:00 am to 5:00 pm Central Standard Time).**

### Cleaning the Bed

Follow these steps for keeping your Medline bed in clean condition:

1. Unplug the full or semi-electric bed before cleaning.
2. Medline beds should **not** be washed down with a pressure washers or steam cleaner. Doing so can result in problems with the electrical system.
3. Inspect bed components for any exposed metal. To prevent rusting, Medline recommends covering exposed metal areas with touch-up paint. Contact Medline Bed Technical Support for paint.
4. Electrical components (motor, junction box, and pendant which are rated as IP66), frame and head board/foot boards are washable with standard water pressure.
5. The headboard and footboard should be disconnected from the frame before cleaning. When cleaning the headboard and footboard, stand them in an upright position, and use a mild detergent and soft cloth. Gently scrub all exterior surfaces. The headboard and footboard can be rinsed thoroughly with warm water. Do not exceed a water temperature of 110 degrees F.
6. Thoroughly dry all bed parts and components.
7. Disassemble the headspring and footspring assemblies before washing. When cleaning headspring and foot spring assemblies, stand the assemblies on edge and wash with a mild detergent. Using a soft sponge or brush, scrub all exterior surfaces. Rinse thoroughly, then completely towel dry all components.
8. To disinfect the bed, wipe down all surfaces of the bed with a disinfectant and allow to dry completely.



## **BED MAINTENANCE**

### **Inspecting the Bed**

The following maintenance procedure should be followed on an as-needed basis:

1. Inspect casters to ensure they roll and lock properly.
2. Inspect pull tubes and motor drive shafts to ensure they are not bent, damaged or excessively worn.
3. Inspect headspring and foot spring sections for excessive wear, bent parts, or other damage.
4. Inspect all welds for cracks.
5. Check all spring decks to ensure links are in place and are not damaged.
6. Inspect all bolts and rivets to ensure they are tight and are not damaged.
7. Inspect all other mechanical parts to ensure there is no damage or excessive wear.
8. Inspect all bed motions: headspring raises/lowers properly, foot spring raises/lowers properly, bed height raises/lowers properly.
9. Ensure all electrical cables have no insulation damage and connectors are in proper working order.
10. Inspect the electrical junction box to ensure there are no cracks and the electrical power cord is not damaged.
11. Inspect all electrical bed components for damage or excessive wear (i.e. cracked or broken housing, worn components.)
12. Inspect pendant, power, and motor cords for excessive wear, insulation damage, or cuts.
13. Inspect all bolts that are at hinge points. Apply a minimal amount of lithium grease if needed.
14. Check the center drive shaft to ensure it is not bent and the ends are in good condition.

## TROUBLESHOOTING GUIDE

PROBLEM	POSSIBLE CAUSE	CORRECTIVE ACTION
Nothing happens when the button is pressed on the patient hand control pendant.	Bed is not plugged in.	Plug the bed's power cord into an electrical outlet.
	Fuse is blown or your home's circuit breaker is tripped.	Check fuse or circuit breaker.
	Motor's thermal switch was tripped.	Let motor cool down and try again.
	Hand control is not connected to the motor control box.	Check to be sure pendant control is properly plugged in to the junction box.
	Power cord, junction box, hand control cord or cables are damaged or defective.	Call your Medline dealer for service and repair.
	End of stroke is reached.	Operate opposite button.
	Cords are not properly connected to the junction box.	Ensure cords are seated securely in the appropriate receptacle.
	Motor will not function after other possible causes have been eliminated.	Call your Medline dealer for service and repair.
The head (or foot) of the bed is always higher than the other end of the bed.	The bed ends were not leveled when the bed was assembled.	See instructions for "Leveling the Bed".
	Two footboards (or headboards) were used instead of one of each. Or, headboard and footboards are switched incorrectly.	Headboard is taller than footboard; check and exchange.
Only headboard (or footboard) raises when Hi-Lo adjustment is made.	The pin in the middle of the center drive shaft has fallen out, allowing the shaft to collapse and disengage.	Replace the pin and reconnect the center drive shaft into the shaft ends.
	The center drive shaft ends are not properly engaged with the pins at each end.	Check both ends of the drive shaft for proper connection.
	One or more of the pins in the center drive shaft have broken.	Call your Medline dealer for service and repair.
	Damaged mechanism inside the bed boards.	Call your Medline dealer for service and repair.
Back or knee section will not raise or lower even though you turn the crank.	There are internal problems with the drive shaft mechanism.	Check to see that the drive mechanism has been properly installed. May need to call your Medline dealer for service and repair.
	The pull tube is not correctly installed.	Ensure pull tubes are correctly connected. Check for binding. May need to call your Medline dealer for service and repair.
Hi-Lo function does not work	Manual and semi-electric beds: crank not properly installed. Full electric bed: drive shaft disconnected.	Check/reinstall drive shaft. Ensure cord is in proper place on junction box. May need to call your Medline dealer for service and repair.
Pressing hand control buttons results in motion other than intended	Motor cable connections to junction box are incorrect.	Verify cable connections to the junction box are in the correct receptacle.

## LIMITED WARRANTY

### The Medline Home Care Bed Limited Warranty

The Medline Home Care Bed mechanics and electronics are warranted to be free of defects in materials and workmanship for five (5) years for the original purchaser. Welds and frames are warranted for the life of the bed.

In the event of a defect covered by this warranty, we will, at our option, repair or replace the bed. This warranty does not cover failure due to owner misuse or negligence, or normal wear and tear.

This warranty does not extend to non-durable components, such as casters, which are subject to normal wear and replacement. This warranty gives you specific legal rights and you may have other rights which vary from state to state.

If you have any questions regarding your Medline Home Care Bed or this warranty, please call us Toll Free at: 1-800-MEDLINE (1-800-633-5463).

#### **Please Note:**

##### **Semi Electric bed:**

Two motors raise and lower the Head Spring and Foot Spring assemblies of this Split-Spring Home Care Bed. These two motors are controlled by a Hand Pendant that is used by the patient or care-giver to adjust the bed to either a comfortable or functional position for its user. The two motors run on 24 volts DC with an onboard transformer to convert the 120 volt AC power. A handle located at the foot of the bed manually controls the bed height.

##### **Full Electric bed:**

Three motors raise and lower the Head Spring assembly, Foot Spring assembly and the bed height of this Split-Spring Home Care Bed. These three motors are controlled by a Hand Pendant that is used by the patient or care-giver to adjust the bed to either a comfortable or functional position for its user. The three motors run on 24 volts DC with an onboard transformer to convert the 120 volt AC power.

The Medline Home Care Bed can be prescribed by Physicians and has been designed for Home Care rehabilitation and extended care applications.



**[www.medline.com](http://www.medline.com) 1-800-MEDLINE**

2009 All rights reserved. Medline is a registered trademark of Medline Industries, Inc.  
Medline Industries, Inc., One Medline Place, Mundelein, IL 6060 USA

Rev. 021109CB